

CAD FILE:

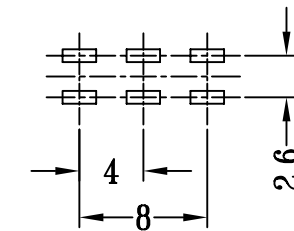
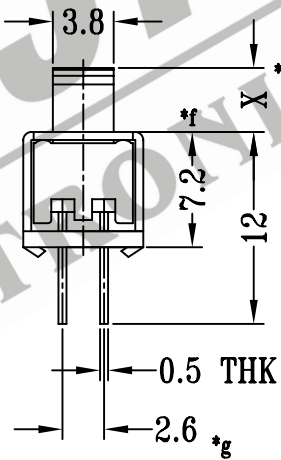
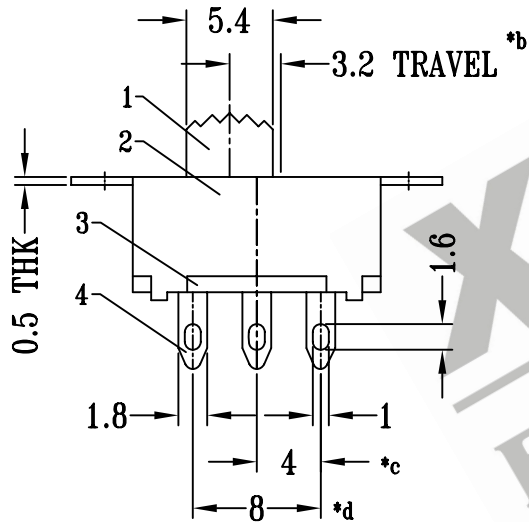
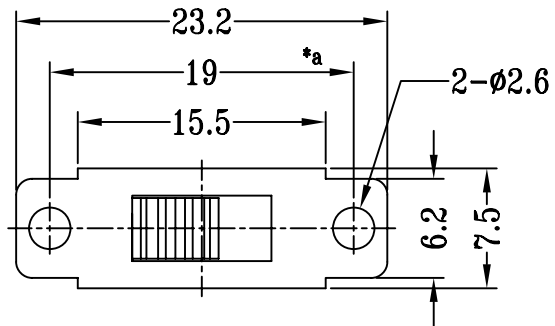

SCHEMATIC (NON-SHORTING)

P.C.B LAYOUT

注:带"*"表示关键尺寸(7个)

NO.	PART NAME	MATERIAL	Q'TY	FINISHING	TOLERANCE UNLESS SPECIFIED	SHENZHEN XIEJIA ELECTRONICS CO.,LTD.				
8						SHENZHEN XIEJIA ELECTRONICS CO.,LTD.				
7										
6	SPRING	STEEL WIRE	2	TEMPER	WITHIN: 1.5±0.1mm	ISSUE	DATE	DESCRIPTIONS		APPD.
5	CONTACT CLIP	BRASS STRIP	2	Ag PLATED	OVER : 1.5±0.2mm					
4	TERMINAL	BRASS STRIP	6	Ag PLATED OVER Ni PLATED	TITLE : VERTICAL SLIDE SWITCH		UNIT : MM	DRWG NO.: XJ-DR-SS22F38-00		
3	BASE	PHENOLIC RESIN	1	BLACK	MODEL: SS-22F38		SCALE: 2 : 1	DWN.	ZHOUYU	2005-7-28
2	FRAME	STEEL STRIP	1	BLACK	ALL MATERIALS MUST BE COMPLIANT TO ROHS		CHK'D	FANGYING	2005-7-28	
1	KNOB	POM	1	BLACK			APPD.	KANGXINAN	2005-7-28	